

Cell Router Setup for use with Static IP Devices (Teltonika brand)

On Advantage Controls routers, the built-in DHCP Server is used to assign IP addresses to computers and other devices on your local area network. Under certain circumstances, it may be necessary to operate the router with DHCP disabled. This guide describes the procedure to configure the Advantage Controls router.

Settings at a Glance:

Computer settings:

IP Addresses: 192.168.1.(2-254)

Subnet Mask: 255.255.255.0

Default Gateway: 192.168.1.1

Preferred DNS: 192.168.1.1

Router Settings:

IP Address: 192.168.1.1

Subnet Mask: 255.255.255.0

Important: You will need to know the APN of the cell service that provides the SIM cards.

Router Configuration:

Step 1:

Connect to the router via ethernet, with either a laptop or desktop computer.

You will need to type the default IP into the web address bar: 192.168.1.1

Step 2:

This will bring up the router login page.

Enter the login credentials.

Note: Default username is “admin” and the default password is located on the back of the router. Once you enter the default password, you will be prompted to enter your own password.

Step 3:

Once you are logged in, you will see the status, overview, system, network, etc. landing page.

Step 4:

Click on the gear icon next to MOB1S1A1(Main) near the middle of the screen. This will load the mobile settings.

Step 5:

The next screen could be one of two screens.

A. Interfaces: MOB1S1A1

If Auto APN is on, turn it off, and enter the custom APN from the cell carrier. Click save and apply.

B: Network Interfaces

1. WAN
2. WAN6
3. mob1s1a1

Next, click on the pencil icon to the right of *mob1s1a1*. This will get you to the same screen (as clicking the gear on the main screen). If Auto APN is on, turn it off, and enter the custom APN from the cell carrier. Click save and apply.

Note: Once the APN is entered, the router should connect within about 5 to 10 minutes.

See back for additional trouble shooting tips.

Additional Troubleshooting:

Open front panel of ROUTER-3 to reveal connections and LED lights.

LED	Description	
A - Service LED	Indicates LTE interface availability and use. * Allow up to 5 minutes for the connections to WebAdvantage & the cellular network to be established.	Off = No Cellular Service
B - Signal LED	Indicates strength of cellular signal.	Strength weak (left) to strong (right))
C - Power LED	Device power indicator.	Off = No Power Green = Powered

General	Description	
D - WIFI antenna	Not used	
E1 - Mobile antenna	Antenna Connection * Antenna wire length approx. 9 ft. E2 not used.	<ul style="list-style-type: none"> - Ensure cable is properly threaded. - Check for frayed or damaged wire. - Move to location optimal for cell reception. - Do not splice antenna wire to extend length. Instead, extend CAT5 up to 328 ft. max.
F1 - Ethernet	CAT5 connection to controller. F2 not used. F3 status indicator light.	CAT5 can be extended up to 328 ft. before signal repeater is required.
G - Power Cord	* Only use supplied power cord.	
H - SIM Card Tray	Mini-SIM (2FF). H2 will eject tray. * SIM edge must match SIM card slot.	
I - Reset (Pin Hole)	Not used	

Note:

Please have ID number available when calling in for troubleshooting. This allows us to identify the specific line and carrier.

The ID number can be found inside of the ROUTER-3 enclosure, attached to the top of the cell router.

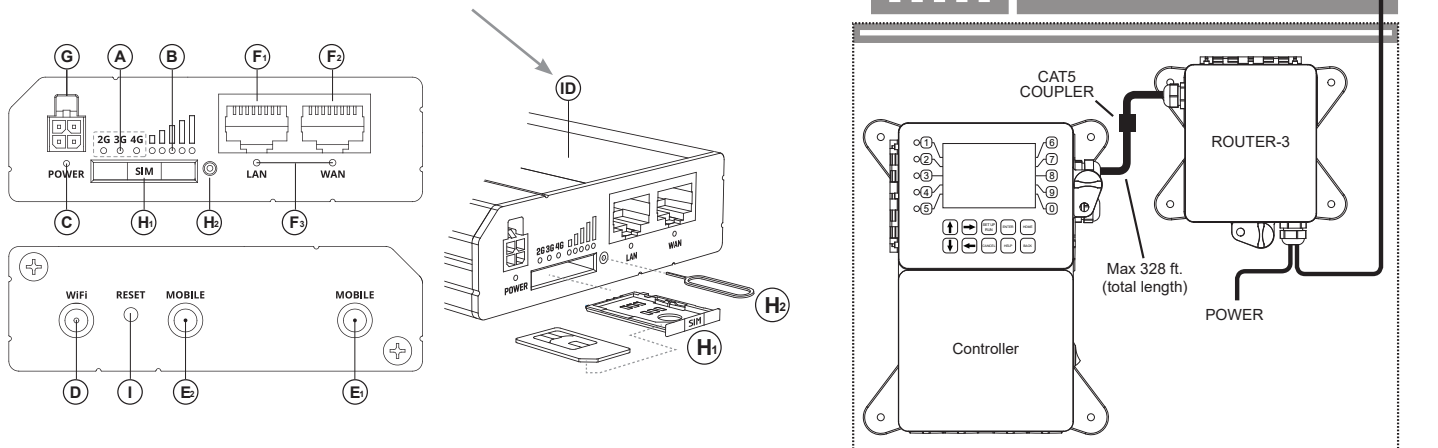

Get the Advantage



4700 Harold Abitz Dr
Muskogee, OK 74403
918-686-6211 phone
918-686-6212 fax
www.advantagecontrols.com