

Series 75 Controller



Installation Maintenance Repair Manual

Advantage Controls
4700 Harold-Abitz Dr.
Muskogee, OK 74403
Phone: 800-743-7431
Fax: 888-686-6212
www.advantagecontrols.com
email: support@advantagecontrols.com

01/2021

Series 100 Controller Manual

Table of Contents

Contents	Page
I. Introduction	3
II. Installation.....	3
Quick Connect Terminal Wiring.....	4
III. System Operation	5
IV. Warranty and Factory Service Policies	6

I. Introduction

The Advantage Controls Series 75 RO controller is designed for the small commercial Reverse Osmosis system. This controller incorporates relay outputs and dry contact inputs to either run or shutdown as necessary for proper operation. The S75 Controller has up to three relay outputs: inlet solenoid valve, RO pump motor, and an optional flush solenoid valve.

II. Installation

1. The RO pump motor or motor starter and the solenoid valves must be of the same voltage 120 or 240 volt.
 2. Confirm that the (3) input signals - pressure switch, tank level switch and pretreat switch are all of the same configuration, normally open or normally closed.
 3. Confirm the desired switch settings for your operation. The switches are factory set to the OFF Position: Auto Reset (disabled), Pressure Fault Retry (disabled), Tank Full restart time delay (2 seconds), Input contact type (NC, open to operate). If you desire to change any switch functions, move that switch to the ON Position. [See table below].
 4. Wire to the controller as follows:
 - Remove the enclosure cover.
 - Mark and drill necessary electrical entry holes in the empty enclosure.
 - Terminate necessary wiring to the Quick Connect terminals as required (See diagram on page 4). Each terminal is labeled for the proper connection. Terminals P1-P9 are high voltage for power, motor, inlet and flush solenoid. Utilize proper 3 conductor wire size for the appliance.
-  **WARNING:** The controller is rated for maximum 20 amp total load. Terminal strip P11 is dry contact for input signals from tank full, pressure fault and pretreat lockout. Use small gauge 2 conductor cable for these wire connections.
5. Position and mount the enclosure in the desired location.
 6. Connect all wiring to the appropriate appliances (**Do not connect to the power source at this time**).
 7. Reassemble the enclosure, be sure to coil and leave some slack wire inside the enclosure.
 8. Connect the power wire 120- 240 volt to its source.
 9. Proceed to push the power switch ON and test the completed unit as necessary.
 10. Notice the status LED to confirm system status.

SWITCH	Off Position	On Position
1	AUTO RESET DISABLED	AUTO RESET ENABLED
2	RETRIES DISABLED	RETRIES ENABLED
3	2 SEC RESTART	15 MIN. RESTART
4	N.O. SWITCHES	N.C. SWITCHES
5	FLUSH OFF	FLUSH ON
6	FLUSH TF	FLUSH ET

 **WARNING:** All switch inputs must be dry contact only. If voltage is applied to these inputs, damage to the controller will result. For power with neutral and hot leads, L1 is hot and L2 is neutral.

Quick Connect Terminal Wiring

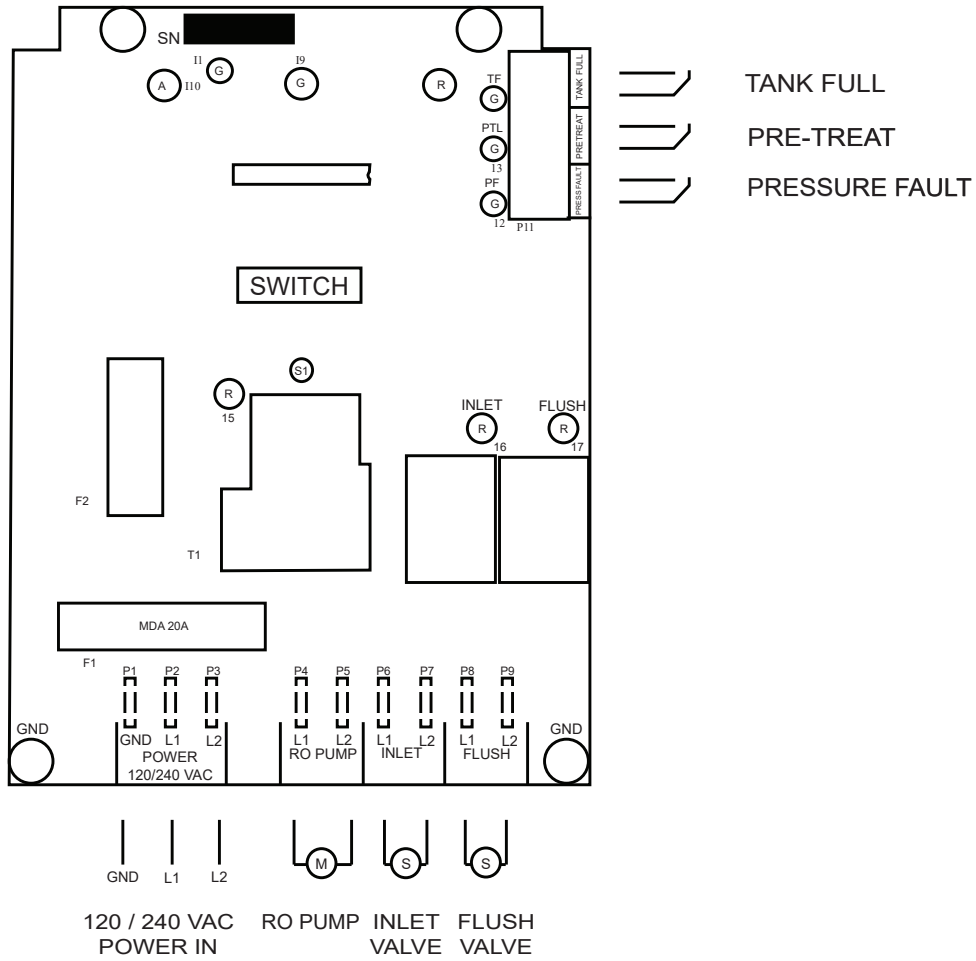

CAUTION

1. There are live circuits inside the controller even when the power switch on the front panel is in the OFF position. Never open the front panel without first disconnecting power from the outlet. Prewired controllers are supplied with an 8 foot, 18 AWG power cord with USA style plug. A #1 Phillips driver is required to open the front panel.
2. Low voltage signal wires (probes, flow switch, water meter, etc.) should never be run in conduit with high voltage (like 115VAC) wires.
3. Never attempt to land connections to the controller without first disconnecting power from the outlet.
4. Do not block access to disconnect power during mounting and installation.
5. The controller should be connected to its own isolated circuit breaker, and for best results, the ground should be a true earth ground, not shared. Any attempt to bypass the grounding will compromise the safety of users and property.
6. The electrical installation of the controller must be performed by trained personnel only and conform to all applicable National, State and Local codes.
7. Operation of this product in a manner not specified by the manufacturer may result in damage to equipment or persons.
8. Avoid mounting in locations that expose the controller to direct sunlight, vapors, vibration, liquid spills or extreme temperatures; less than 0°F (-17.8°C) or greater than 120°F (50°C). EMI(electromagnetic interference) from radio transmissions and electric motors can also cause damage or interference and should be avoided.

III. System Operation

When the power switch is turned ON, the center status LED will flash Green, the inlet valve will OPEN and the RO pump will START. The center LED will be solid Green for normal run.

Under normal operation the RO unit will run until: (A) the storage tank is full (left status LED Amber) or (B) Pretreat lockout has occurred (center status LED Flashing Green). When A or B has cleared, after a time delay, the RO unit will restart, and the status LED will return to Green. Switch setting 3 selects a 2 second or 15 minute tank full restart time delay.

Upon an alarm signal for Pressure Fault, the left status LED will flash Red, the RO pump will stop and the inlet valve will close and the RO pump will turn OFF.

If switch 1 and 2 are in the OFF Position (disabled), the left status LED will be a steady RED and the RO will not restart until the Power Switch has been manually cycled OFF then ON to reset the unit.

If switch 1 is in the ON Position (auto reset), every 60 minutes the RO will start and stop again if a pressure fault continues.

If switch 2 is in the ON Position (pressure fault retry), the RO will attempt to restart after 30 seconds, then 5 minutes, then 30 minutes. If the pressure alarm has not cleared after the third try, the RO unit will remain off until manually reset.

If switch 1 and 2 are in the ON Position, after a pressure fault condition, the RO unit will continually attempt to restart after each 60 minute cycle, until the pressure switch input has cleared.

If switch 5 is in the OFF position, Flush is disabled; in the ON position, Flush is enabled.

If switch 6 is in the OFF position, the unit will flush on Tank Full. In the ON position, flush is every 24 hours elapsed time.

Flush time is 5 minutes. The Amber Flush LED will flash.

Switch 4 is for switch inputs. OFF is for N.O. contacts. ON is for N.C. contacts.

IV. Manufacturer's Product Warranty

Advantage Controls warrants to the original purchaser that the products it manufactures will be free from defects in material and workmanship for a period of twelve months from the date of shipment on parts and ninety days on labor. Some non-Advantage manufactured resale items may have warranty periods less than twelve months. Advantage Controls' obligation under this warranty is limited exclusively to the repair or replacement of any product that Advantage finds to be defective. Items returned for warranty consideration must have a return authorization number and be properly packaged, shipped prepaid and insured. This warranty is valid only when the products are properly installed, maintained and used for the purpose for which they were designed. Misuse, neglect, damage, accident, improper repair, or modification not authorized in writing by Advantage Controls will void this warranty.

There are no warranties, expressed or implied, including the implied warranties for merchantability or fitness for a particular purpose that extend beyond the limited warranty expressly stated above. Advantage Controls' liability to any purchaser of its products, whether in contract or in tort, and whether arising out of warranties, representations, instructions, installations, or defects from any cause, will be limited exclusively to repairing or replacing the product or any part thereof under the conditions set out above.

30 Day Billing Memo Policy

Advantage Controls maintains a unique factory exchange program to ensure uninterrupted service with minimum downtime. If your controller malfunctions, call 1 (918-686-6211 (international customers dial +1 918 686-6211), and provide our technician with Model and Serial Number information. If they are unable to diagnose and solve your problem over the phone, a fully warranted replacement unit will be shipped, usually within 48 hours, on a 30 Day Billing Memo. This service requires a purchase order and the replacement unit is billed to your regular account for payment. The replacement unit will be billed at current list price for that model less any applicable resale discount. Upon return of your old unit, credit will be issued to your account if the unit is in warranty. If the unit is out of warranty or the damage not covered, a partial credit will be applied based upon a prorated replacement price schedule dependent on the age of the unit. Any exchange covers only the controller or pump. Electrodes and other external accessories are not included.

Get the Advantage in Water Treatment Equipment

Advantage Controls can give you the *Advantage* in products, knowledge and support on all of your water treatment equipment needs.

- Cooling Tower Controllers
- Boiler Blow Down Controllers
- Blow Down Valve Packages
- Solenoid Valves
- Water Meters
- Chemical Metering Pumps
- Corrosion Coupon Racks
- Chemical Solution Tanks
- Solid Feed Systems
- Feed Timers
- Filter Equipment
- Glycol Feed Systems
- Pre Fabricated Systems

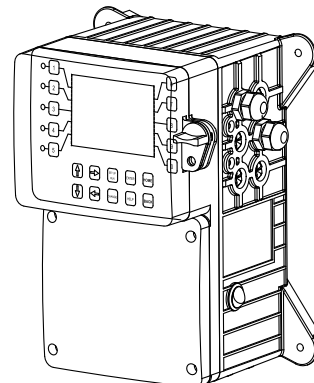
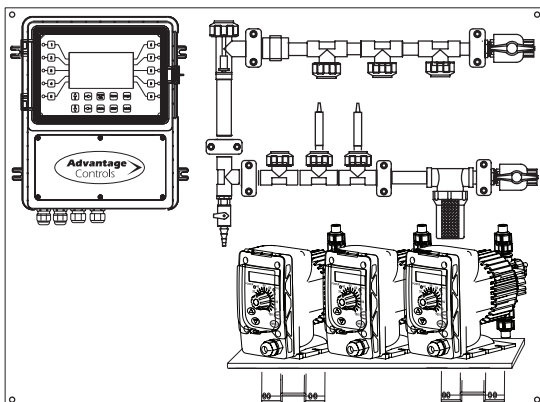
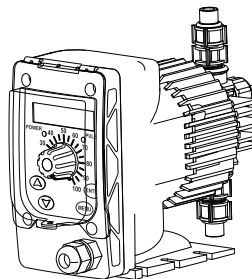
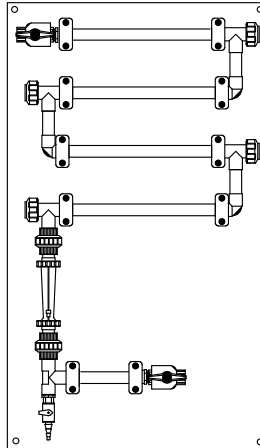
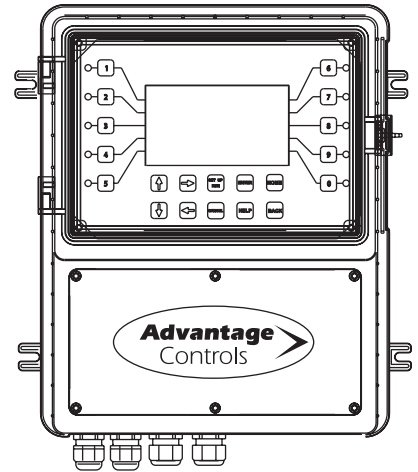
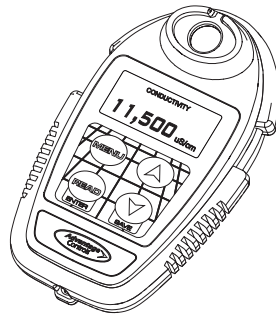

Get the Advantage



