

Model GF Digital Glycol Feeder with NANO

*Installation
Maintenance
Repair
Manual*

Advantage Controls
4700 Harold-Abitz Dr.
Muskogee, OK 74403
Phone: (918) 686-6211
Fax: (888) 686-6212
www.advantagecontrols.com

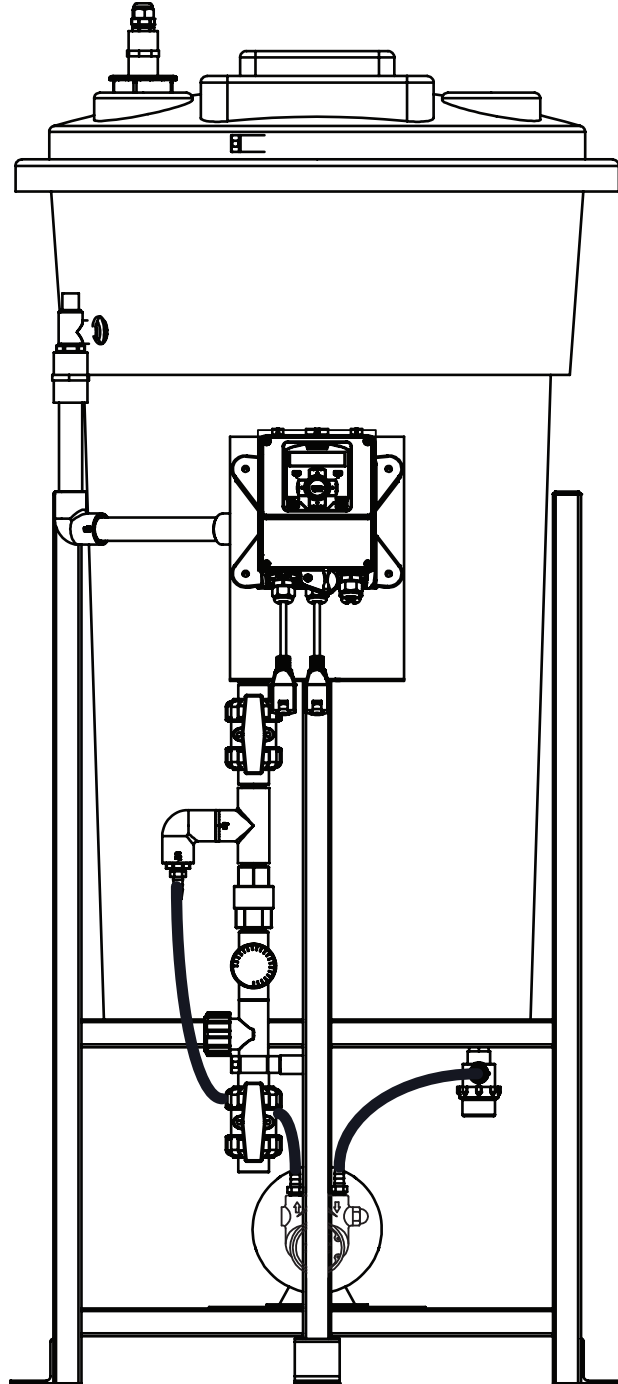

05/2025

Table of Contents

I.	Introduction	2
II.	Model Numbering and General Specifications.....	3
III.	Installation.....	4
	Electrical Wiring	4
	Mounting Instructions	4
	Typical Installation and Measurements	5
	Relay and Logic Cards.....	6
	Start Up and Test Procedure / Recommendations.....	7
IV.	Front Panel Description	7
V.	System Operation Overview	7
	Description of Set Up Menus	7
VI.	NanoTron mA Menu Map.....	8
VII.	Parts List.....	10
VIII.	Troubleshooting and Maintenance.....	11
IX.	Warranty	13
	Reference Chart % Propylene Glycol.....	14
	Reference Chart % Ethylene Glycol.....	14

I. Introduction

The Advantage Controls Glycol Feed Systems are design to regulate pressure in closed loop Hydronic Heating and Cooling applications.

Advantage Controls micro-processor base controller reads a solid state pressure transducer, displays system pressure, and uses a keypad for the entry of control parameters. The micro-processor has built in real-time clock and memory back-up for all user settings, in case of power interruptions. Setting for all functions are made using the keypad, readings are displayed on a back lit 16 character alphanumeric display.

Advantage Controls Glycol Feeders are stand alone pre-wired, pre-plumbed systems designed for ease of installation. Our systems are mounted on a powder coated steel frame with anchor points.

Advantage Controls Model Designation allows for a wide variety of configurations, operation and function of each Glycol Feed Systems this is dependent on your specific model number. Please check your model number against the selection guide for better understanding of your system.

Please read this instruction manual to become familiar with your system.

II. Model Numbering and General Specifications

BUILD A MODEL

GF - _____ - _____

TANK SELECTION

- 0 = No tank
- 1 = 55 gallon poly
- 2 = 100 gallon poly
- 3 = 30 gallon poly
- 6 = 70 gallon poly
- 7 = 150 gallon poly

STAND SELECTION

- A = Powder Coated steel stand
- B = Powder Coated steel stand w/ mixer bracket

PUMP SELECTION

- 0 = No pump
- 1 = 2.0 gpm at 150 PSI; 1/3 hp
- 2 = 3.3 gpm at 150 PSI; 1/2 hp
- 3 = 5.5 gpm at 100 PSI; 1/2 hp
- 4 = 10 gpm at 100 PSI; 1 hp

PUMP CONFIGURATION

- A = Standard configuration
- B = Alternating pumps for single loops
(requires 2 pump selections)
- C = Pump plumbed for transfer duty into tank

LOOP SELECTION

- 0 = No loop
- 1 = Sch 80 PVC loop; 100 PSI max; 100°F max
- 2 = Copper/brass loop; 100 PSI max; 180°F max
- 3 = Carbon steel loop; 100 PSI max

CONTROL SELECTION

- M = ETL listed NANO-N with alarm buzzer and dry contact

OPTIONS

- 1 = 240V
- 5 = Position backcheck to use tank for expansion
- H = 0-200 PSI pressure transducer and gauge
- M = Mixer controls (order mixer separate)
- S = On/Off switch for pump only (already included with control option E)
- R = Roller casters added to stand

Most units include poly tank and stand, low level switch with audible alarm (100db) with silence switch, dry contact alarm, pressure relief valve and plumbing assembly with pressure gauge.

NOTE: Pump selections represent models built after 03/2021.

III. Installation

Electrical Wiring

The standard digital glycol feeder controller has an internal regulated power supply that will operate in the range of approximately 100 to 250 VAC on the incoming wiring. Output relay(s) are protected with a replaceable fuse. Each relay's output voltage will equal incoming line voltage. The Standard prewired units are supplied with a 8 foot, 16 AWG, 3 wire grounded, 120 VAC USA power cord for incoming power.

NOTE: Liquid tight fittings and labeled signal lead cables are provided for all signal (low voltage) connections, low drum level and pressure transducer.



WARNINGS:

- 1. The controller should be connected to its own isolated circuit breaker, and for best results, the ground should be a true earth ground, not shared. Wiring must be done according to all applicable local codes.**
- 2. Power (line voltage) must be disconnected while making any connections. If power is supplied to the unit, line voltage will be present on the relay cards.**
- 3. Low voltage signal wires (transducer, level, alarm, etc.) should never be run in conduit with high voltage wires.**

Mounting Instructions

Select a mounting location that provides the operator easy access to the unit and a clear view of the controller. The location should be convenient to grounded electrical connections and system plumbing connections. Mount the glycol feeder stand to a level concrete pad using the ½" mounting holes in the base of the stand. Concrete pad construction and anchoring bolts must comply with local building codes. The required sample line plumbing should be connected to the return header of the Hydronic system



WARNING:

Avoid locations that expose the controller to direct sunlight, vapors, vibration, liquid spills or extreme temperatures; less than 0°F (-17.8°C) or greater than 120°F (50°C). EMI(electromagnetic interference) from radio transmissions and electric motors can also cause damage or interference and should be avoided.

Typical Installation and Measurements

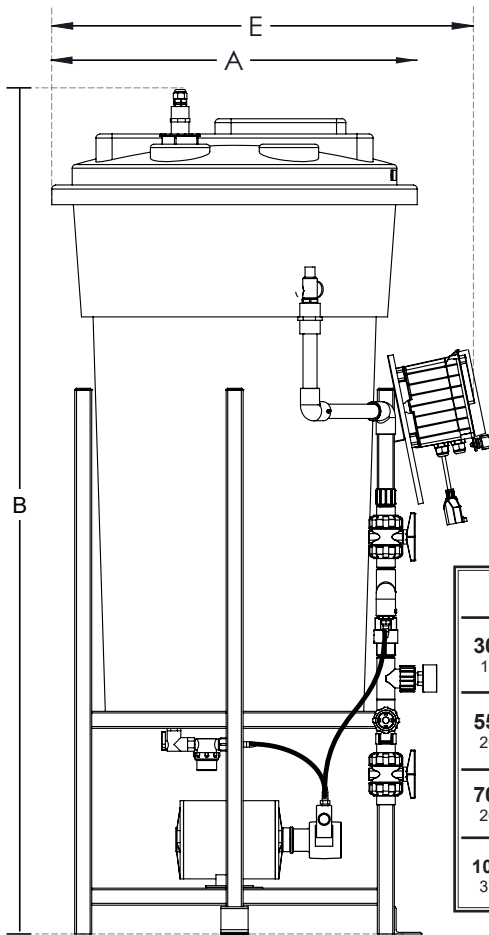
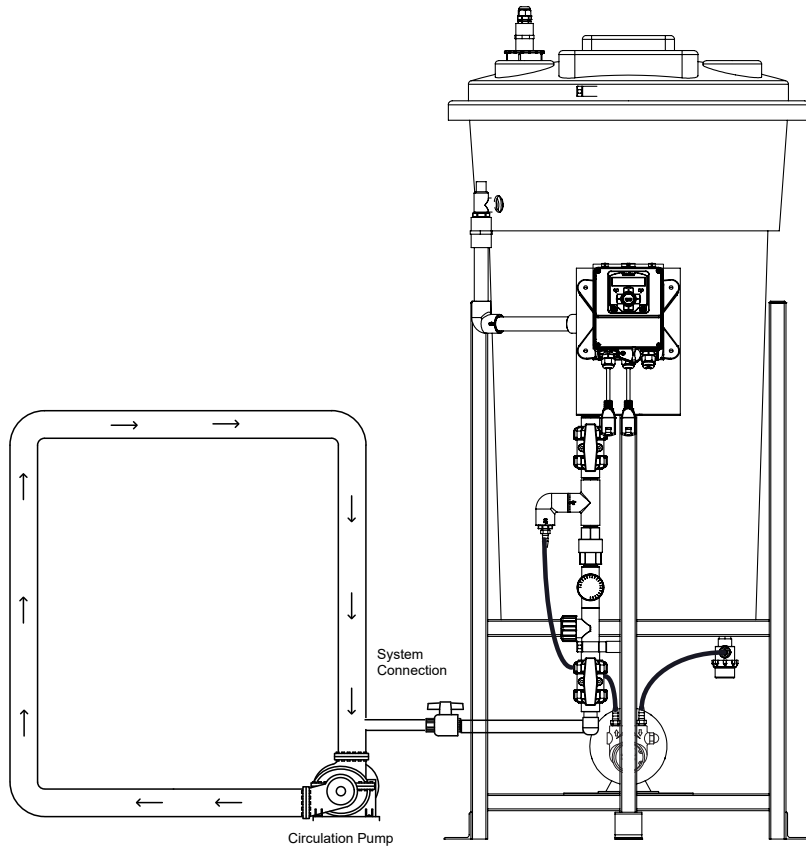

Side View Shown

GLYCOL STAND FOOT PRINT

1/4" bolt hole drilled
3/4" from outside edge

Note: This is for mounting
holes only. Controller will
extend beyond this depth.

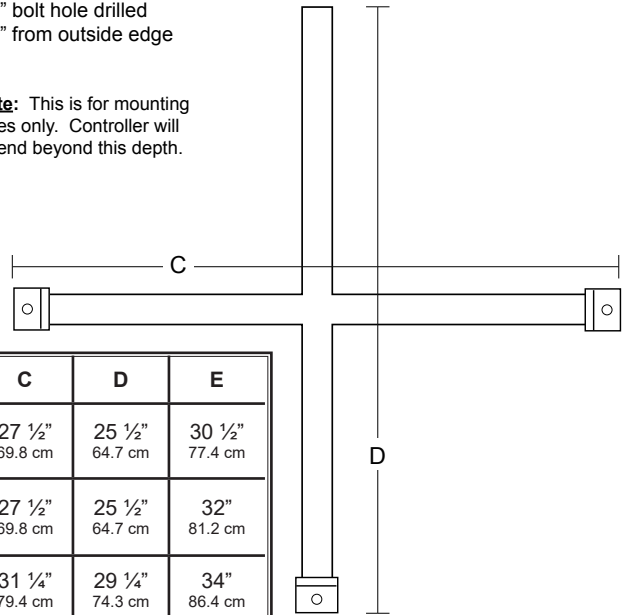

	A	B	C	D	E
30 gal 113.5L	23 3/4" 60.3 cm	51" 129.5 cm	27 1/2" 69.8 cm	25 1/2" 64.7 cm	30 1/2" 77.4 cm
55 gal 208.1L	27 1/2" 69.8 cm	65" 165.1 cm	27 1/2" 69.8 cm	25 1/2" 64.7 cm	32" 81.2 cm
70 gal 264.9L	27 1/2" 69.8 cm	65" 165.1 cm	31 1/4" 79.4 cm	29 1/4" 74.3 cm	34" 86.4 cm
100 gal 378.5L	31 1/4" 79.3 cm	66" 167.6 cm	37" 93.9 cm	35" 88.9 cm	38" 96.5 cm

Relay Card

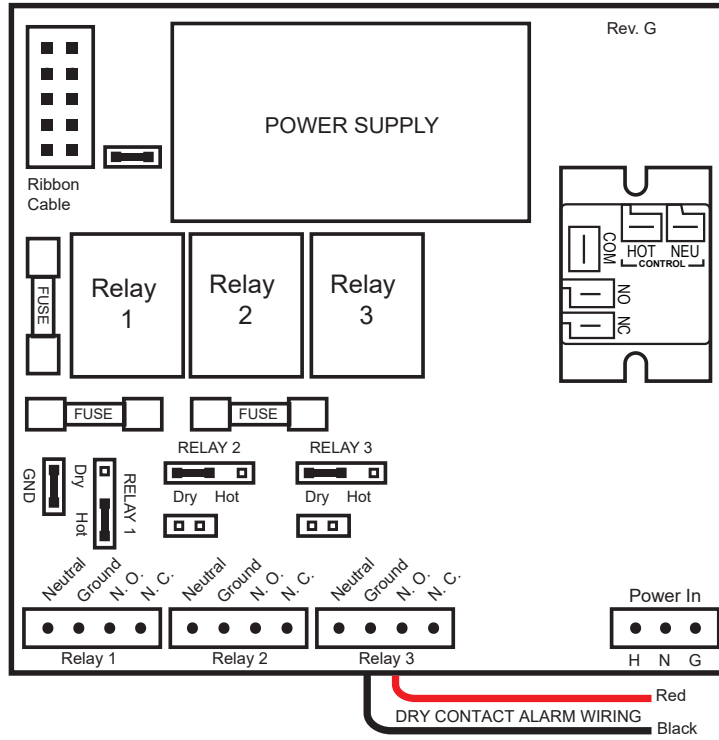

NanoTron-N Logic Card

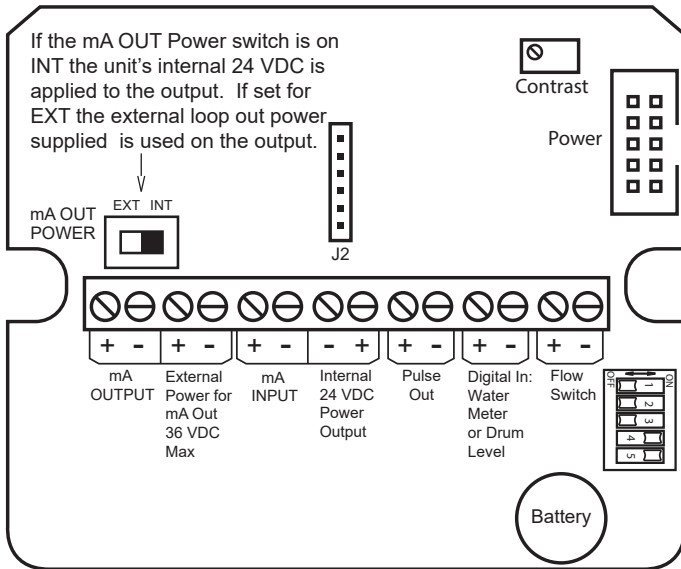

Switch #	Position	Function
1	OFF	Backlight off; flashes on w/ alarm
1	ON	Backlight on; flashes off w/ alarm
2	OFF	Normal Operation
2	ON	"Burn-in" Mode
3	OFF	Normal Operation
3	ON	Resets to factory defaults

Wiring for two-wire pressure sensor that needs 12-24 VDC on loop.

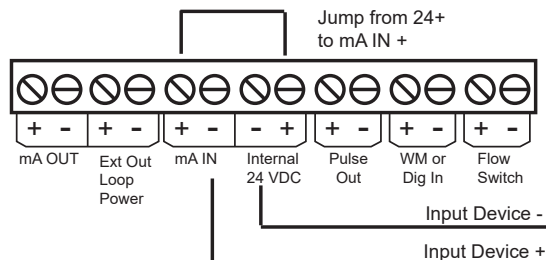

Start Up and Test Procedure / Recommendations

1. Before filling tank, be sure that the tank and the filter bowl are free of packing material and or construction debris.
2. Check plumbing as it may have become loose from vibrations during shipping.
3. Fill Tank
4. Open isolation valve to system.
5. If there are no leaks verify that the pressure gauge agrees with system pressure. This value may vary due to location of the hydronic system connection.
6. Before applying power to the controller, remove fuse from lower relay enclosure. Reasoning behind this is, factory settings may not agree with your system and this gives time for you to set your parameters before applying power to the pump or pumps.
7. Apply power to your system. Confirm all connections.
8. Once you are familiar with the controller from either reading the instruction manual or trial and error. Proceed with setting parameters that are correct for your hydronic system.

IV. Front Panel Description

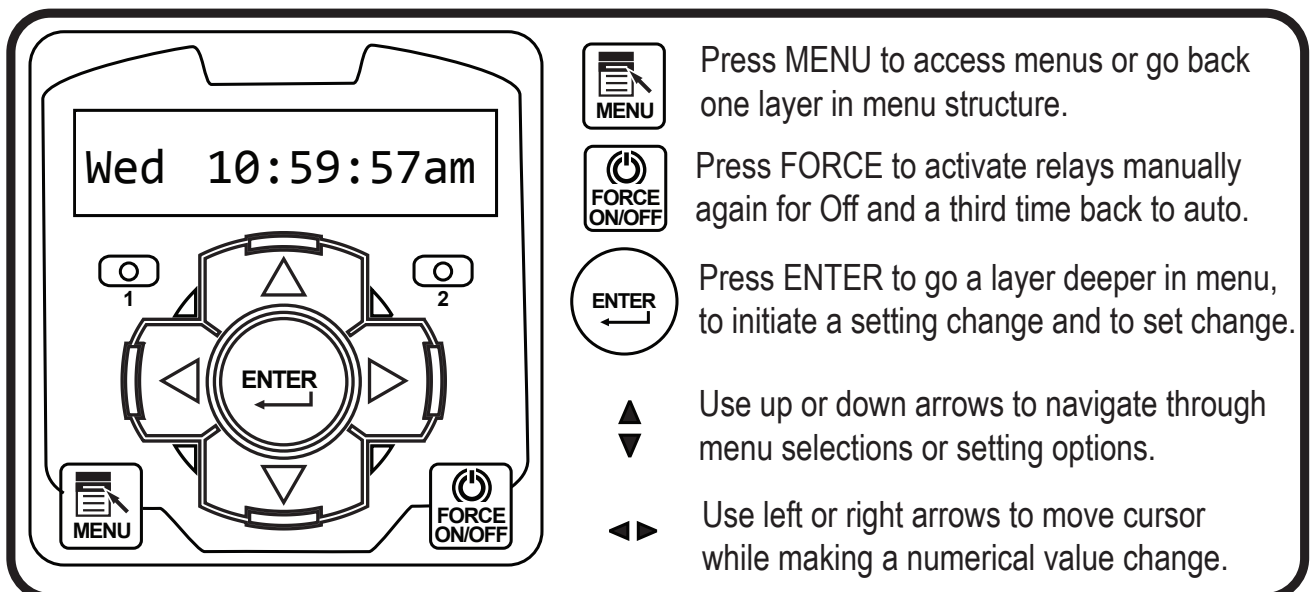

V. System Operation Overview

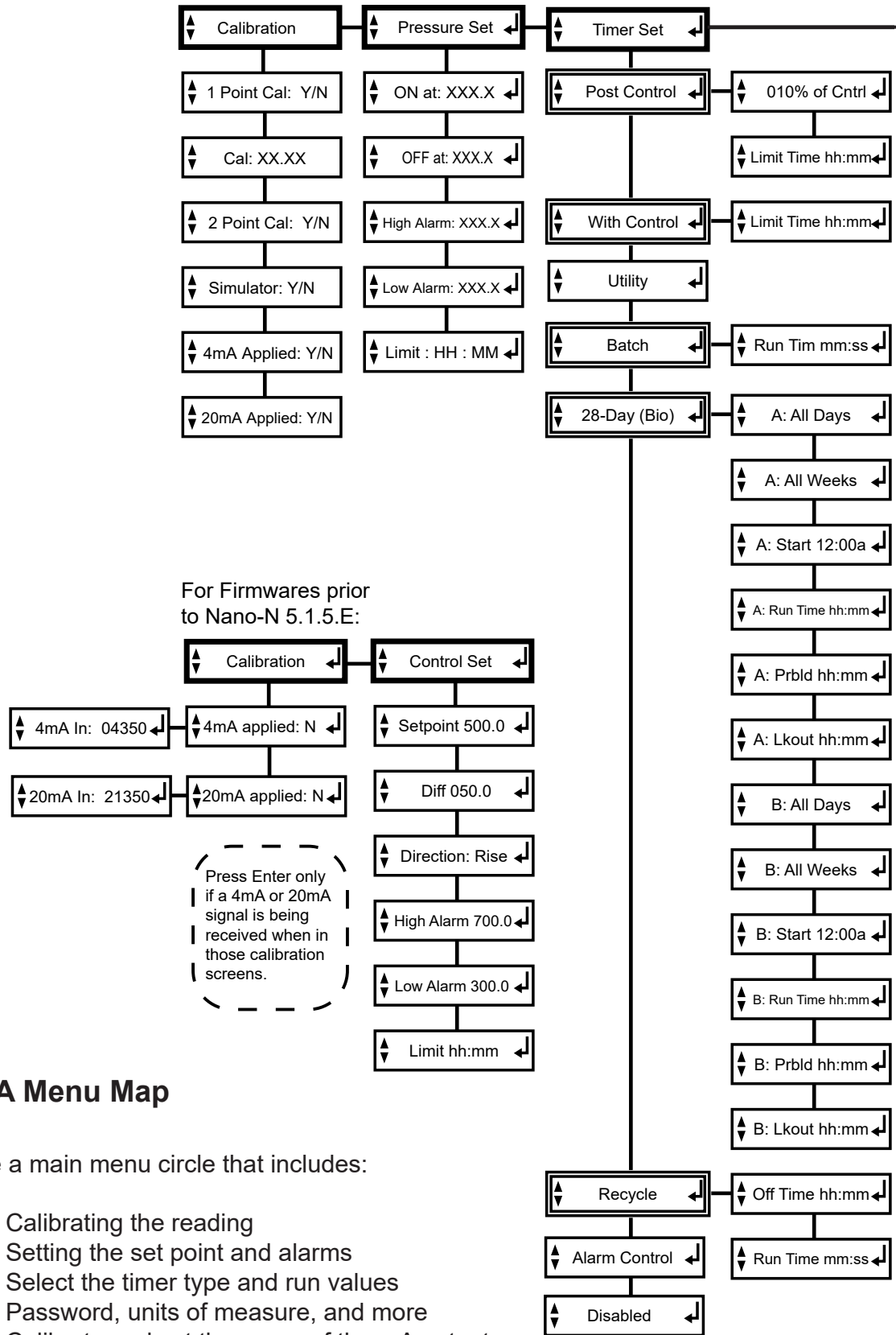

VI. NanoTron mA Menu Map

NanoTron units have a main menu circle that includes:

- Calibration** - Calibrating the reading
- Pressure Set** - Setting the set point and alarms
- *Timer Set** - Select the timer type and run values
- Configure** - Password, units of measure, and more
- *4-20 Output** - Calibrate and set the range of the mA output
- *Pulse Output** - Set the range and speed of the pulse output
- Clock Set** - Set time, date and week
- Force Set** - Set the force on time for manual relay activations
- Diagnostics** - Tests and calibration reset

*Asterixed features are available but not typically used in glycol feeder applications

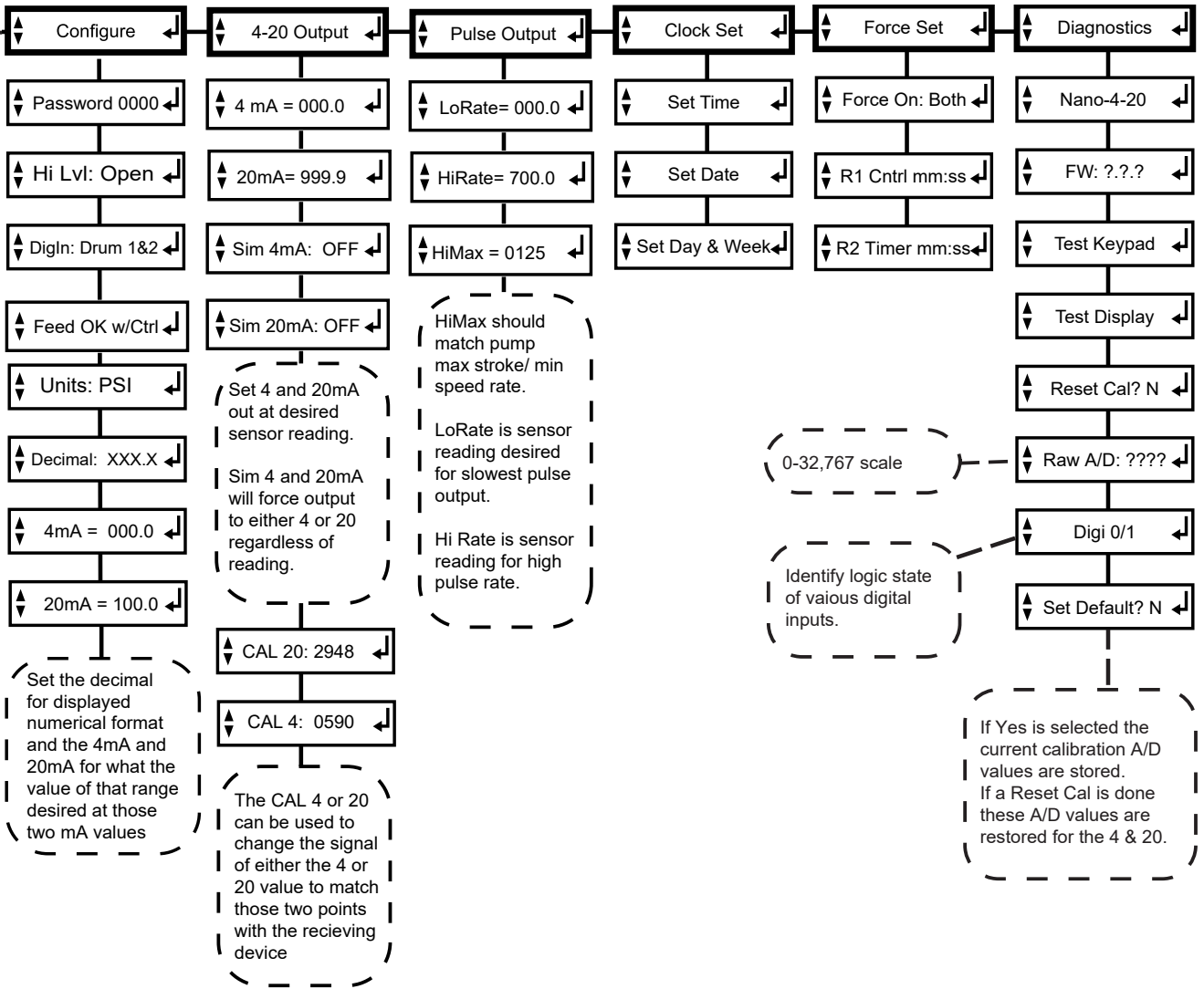

Description of Menu

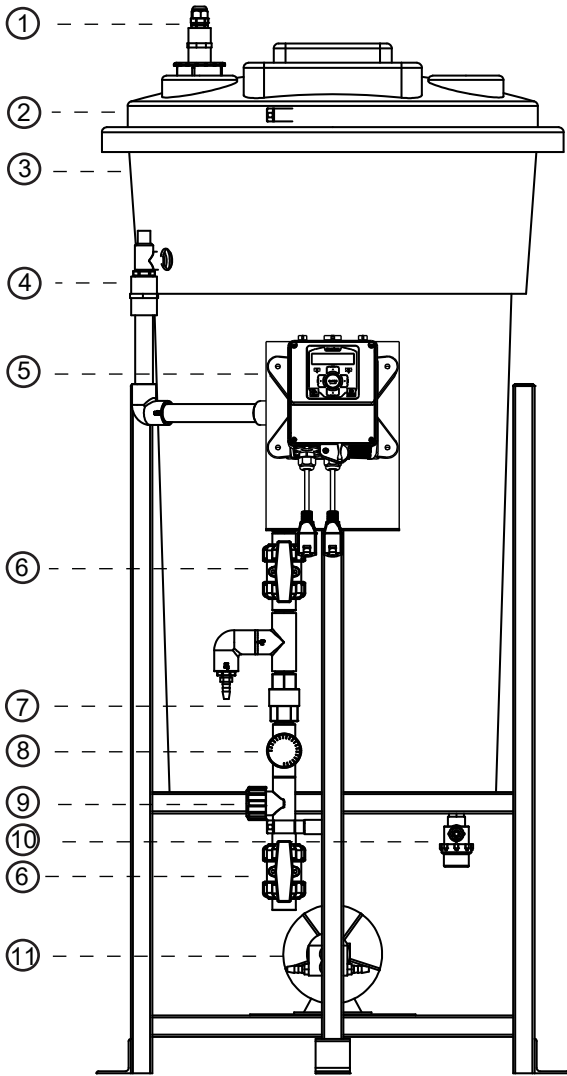

- 4.
- 5.
- 6.
- 7.
- 8.
- 9.
- 10.
- 11.

NanoTron controllers have three modes of operation, Run, Menu and Force. All menus are circular. Pressing the DOWN key will display the next line of information on the display.

Run - This mode is for normal operation. The control relays will only be automatically active in this mode. In the Run mode, the display will read system values. If an alarm is present, the display flashes with the alarm status.

The Run menu will display values such as day, time, date and other values depending upon the features present on the unit. The unit will automatically return to the Run mode if no keys are pressed for three minutes.

Menu - This mode is used to make adjustments to settings and readings on the controller. To access the Menu mode from the run screen, press the Menu key. Use the up or down arrow to scroll through the various menus. When you want to access a specific menu, press the Enter key. Once you have entered a sub-menu you will be able to step through that menu's options with the up or down arrow key.

Force - Relays may be forced on or off for a user defined amount of time. Press the Force key to force relays on for the time configured in the Menu's force sub-menu. Press it a second time to force them off for the same amount of time. Press a third time to go back to automatic Run mode. Unit returns to the Run mode automatically when the force time has elapsed.

VII. Parts List

Parts List

1. Level wand for 30 gl = **ALL-S30**; 55 gl = **ALL-S42**
2. Tank lid for 30 gl = **LID-30-C1D**; 55 gl = **LID-55-C1D**
3. Tank for 30gl = **AGF-APCT-30**; for 55 gl = **AGF-APCT-55**
- Pressure relief valve = **AGF-PRV**
- Glycol feeder controller = **GF-NANO-M**
- Isolation valve = **BV 3/4** for PVC; **GV-3/4** for copper
- Back check = **OKV 3/4PP** for PVC; **SKV-3/4B** for copper
- Pressure gauge = **AGF-PG**
- Pressure transducer = **AGF-PTD** (0-100 psi)
- Suction shut-off and strainer assembly = **AGF-SUCTION**
- Pump = See model number to identify desired replacement pump output
- 1** = **GFPUMP-1** for 2 gpm @ 150 psi
- 2** = **GFPUMP-2** for 3.3 gpm @ 150 psi
- 3** = **GFPUMP-3** for 5.5 gpm @ 100 psi
- 4** = **GFPUMP-4** for 10 gpm @ 100 psi

Note: This list covers most of our popular models.

For models not covered, consult factory.

Pressure Relief Valve Specifications

- Sizes 1/2" and 3/4"
- Inlet (bottom) is male threaded, NPT
- Outlet (side) is female threaded, NPT.
- Buna-N disc on machined body seat.

Gallons per Minute at Pressure					
Model	50 psi	100 psi	150 psi	200 psi	250 psi
GFPUMP-1	2.1	2.05	2	1.95	0
GFPUMP-2	3.6	3.4	3.2	3.1	0
GFPUMP-3	5.51	5.5	5.41	0	0
GFPUMP-4	10.2	10.1	10	9.5	9.2

VIII. Troubleshooting & Maintenance

The Advantage Glycol Feeder is designed for many years of trouble-free operation. Should a problem occur, refer to the following to help identify the problem.

NO POWER TO CONTROLLER

1. Disconnect plug from live receptacle.
2. Remove keypad panel to access relay board in the back of the enclosure (see page 6).
3. Locate green 3 position connector in bottom right corner of board and make sure it is securely plugged in with all three wires tightly screwed down in the connector.
4. Locate logic ribbon cable on left side of relay board and make sure it is securely connected at both ends.
5. Before replacing the panel, do a quick visual of all connections and wiring to ensure no other damage has occurred.
6. Replace panel and secure.
7. Plug in power cord and proceed with Start-up.
8. If power issue was not corrected. Record Model /Serial Numbers and call customer service at 918-686-6211.

PUMP DOES NOT RUN WHEN RELAY INDICATOR IS ILLUMINATED

1. Check fuse and that the fuse holder is secure.
2. Check pump wiring.
3. Check level of fluid / depth of level wand to make sure low level doesn't have it forced off.

PUMP DOES NOT SHUT OFF WHEN TANK IS EMPTY

1. Under the configuration menu, confirm that DigIN is set to Drum 1&2
2. Disconnect level wand connection and short tips together in connector going back to controller (this is low voltage). Alarm should sound and pump stop when the input sees a closed contact.
 - If Yes, inspect end of level wand for debris or damage, replace if needed. The float at bottom of the wand should have free movement, up and down.

- If No, inspect wire for damage. If no damage visible inspect internal wiring (see page 6).
3. If no resolution is found, record Model / Serial numbers and call customer service.

LOW LEVEL ALARM STAYS ON

1. The low level input goes into alarm when there is a closed contact on the input. Disconnect level wand connection and the alarm should go off.
2. If this turns off the alarm. Inspect the float to make sure it is moving freely.
3. If the float is free moving there is a problem with the wand and it should be replaced.
4. If disconnecting the connector does not turn off alarm. Inspect internal wiring (see page 6).
5. If no resolution record Model / Serial numbers and call customer service.

PUMPING PERFORMANCE INSUFFICIENT OR BLOWS FUSE

1. Check if valves are fully open.
2. Check/clean strainer. Prolonged exposure to debris in the glycol may damage pump.
3. If pump has been run dry for a prolonged time, the pump may need to be replaced.

Advantage Controls has used different makes of glycol feed pumps but only offers the newer style rotary vane as a replacement for older models that used a gear pump. The newer pumps may require a new larger suction strainer assembly and tubing. Here are the models and required suction sizing based on the Pump selection code in the model number (see model numbering on page 3):

Pump Code	Replacement	Suction Assembly
1	GFPUMP-1	GF-1-SUCTION includes 1/2" strainer and 3/8" tubing
2	GFPUMP-2	GF-2-SUCTION includes 1/2" strainer and 1/2" tubing
3	GFPUMP-3	GF-2-SUCTION includes 1/2" strainer and 1/2" tubing
4	GFPUMP-4	GF-4-SUCTION includes 3/4" strainer and 3/4" tubing

Maintenance

Maintenance and care will depend upon the usage and environment in which the system is subjected to. The following is the suggested regular maintenance required to keep the glycol feed system operating properly:

TANK AND PLUMBING

Periodically check the piping and tubing to insure proper discharge of the glycol solution. The strainer should be periodically checked for clogging and wear. The level wand should be removed and cleaned to prevent clogging.

FEED PUMP

Check for proper operation. If any pump/motor noises, leaks or changes in operation are detected, the pump should be removed and examined by a certified technician or replaced. Pump repairs can be difficult and should only be attempted by qualified personnel. Improper repairs or assembly can result in pump failure and voiding of the warranty.

PRESSURE RELIEF VALVE

Periodic checking and replacement of the adjustment seal is the only maintenance required.

IX. Manufacturer's Product Warranty

Advantage Controls warrants units of its manufacture to be free of defects in material or workmanship. Liability under this policy extends for 12 months from date of installation for all aspects of the glycol feeder with the controller only covered for an additional 12 months. Liability is limited to repair or replacement of any failed equipment or part proven defective in material or workmanship upon manufacturer's examination. Removal and installation costs are not included under this warranty. Manufacturer's liability shall never exceed the selling price of equipment or part in question. Advantage disclaims all liability for damage caused by its products by improper installation, maintenance, use or attempts to operate products beyond their intended functionality, intentionally or otherwise, or any unauthorized repair. Advantage is not responsible for damages, injuries or expense incurred through the use of its products.

The above warranty is in lieu of other warranties, either expressed or implied. No agent of ours is authorized to provide any warranty other than the above.

30 Day Billing Memo Policy

Advantage Controls maintains a unique factory exchange program to ensure uninterrupted service with minimum downtime. If your unit malfunctions, call 1-800-743-7431, and provide our technician with Model and Serial Number information. If we are unable to diagnose and solve your problem over the phone, a fully warranted replacement unit will be shipped, usually within 48 hours, on a 30 Day Billing Memo. This service requires a purchase order and the replacement unit is billed to your regular account for payment.

The replacement unit will be billed at current list price for that model less any applicable resale discount. Upon return of your old unit, credit will be issued to your account if the unit is in warranty. If the unit is out of warranty or the damage not covered, a partial credit will be applied based upon a prorated replacement price schedule dependent on the age of the unit. Any exchange covers only the controller or pump. Electrodes, liquid end

components and other external accessories are not included.

Reference Chart % Propylene Glycol

Weight % Propylene Glycol	Volume % Propylene Glycol	Freeze Point°F	Refractive Index N _D 77°F	Degree Brix	Boiling Point of @760MM Hg
20	19.4	19.9	1.3565	15.4	213°F
21	20.4	19.0	1.3575	16.0	
22	21.4	28.0	1.3586	16.7	
23	22.4	17.0	1.3598	17.4	
24	23.4	16.0	1.3611	18.4	
25	24.4	15.0	1.3621	18.8	214°F
26	25.3	14.0	1.3632	19.6	
27	26.4	13.0	1.3643	20.2	
28	27.4	12.0	1.3654	20.8	
29	28.4	11.0	1.3664	21.4	
30	29.4	9.1	1.3674	22.0	216°F
31	30.4	8.0	1.3685	22.7	
32	31.4	7.0	1.3700	23.6	
33	32.4	6.0	1.3714	24.4	
34	33.5	4.0	1.3729	25.3	
35	34.4	3.0	1.3742	26.1	217°F
36	35.5	1.0	1.3755	26.9	
37	36.5	0	1.3765	27.5	
38	37.5	-2.0	1.3775	28.0	
39	38.5	-4.0	1.3785	28.5	
40	39.6	-5.0	1.3796	29.1	219°F
41	40.6	-7.0	1.3806	29.6	
42	41.6	-9.0	1.3816	30.2	
43	42.6	-11.0	1.3826	30.7	
44	43.7	-13.00	1.3837	31.3	
45	44.7	-15.0	1.3847	31.8	220°F
46	45.7	-17.0	1.3857	32.4	
47	46.8	-19.0	1.3868	33.0	
48	47.8	-22.0	1.3878	33.5	
49	48.9	-25.0	1.3889	34.1	
50	49.9	-29.0	1.3899	34.7	222°F
51	50.9	-31.0	1.3911	35.5	
52	51.9	-33.0	1.3922	35.9	
53	53.0	-37.0	1.3936	36.6	
54	54.0	-40.00	1.3947	37.2	
55	55.0	-43.6	1.3961	38.0	
56	56.0	-46.0	1.3968	38.4	
57	57.0	-50.0	1.3891	39.1	
58	58.0	-53.0	1.3911	39.6	
58	59.0	-57.0	1.4002	40.3	

- Notes -

Get the Advantage in Water Treatment Equipment

Advantage Controls can give you the *Advantage* in products, knowledge and support on all of your water treatment equipment needs.

- Cooling Tower Controllers
- Boiler Blow Down Controllers
- Blow Down Valve Packages
- Solenoid Valves
- Water Meters
- Chemical Metering Pumps
- Corrosion Coupon Racks
- Chemical Solution Tanks
- Solid Feed Systems
- Feed Timers
- Filter Equipment
- Glycol Feed Systems
- Pre Fabricated Systems

