

LIFTX

Lift Station Monitor

*Cloud-Based Alarming,
Monitoring, and Reporting
of Lift Station Conditions
via WebAdvantage*



**User-friendly, custom
keypad/display for setup,
programming and alerts**



Key Features

- Built-In Cellular Connection
- Remote Alarms, Alerts, & Status
- Customizable Info/Naming
- 5 or 10 Digital Inputs
- Customizable Notepad
- WebAdvantage Reporting
- Optional Totalizing Flow Inputs
- Optional (4-8) 4-20 mA Inputs
- Optional (up to 4) 4-20 mA Outputs

Application

MegaTron LIFTX monitors provide web-based alarming and reporting of remote lift station conditions, such as: high/low level, pressure, temperature, motor current draw, generator switch over, loss of power, security, and more, with WebAdvantage cloud-based remote alarming and reporting.

Units come complete with the first 12 months of cellular service for easy start-up and web connectivity.

WebAdvantage provides web-based access of settings, conditions, e-mail alarming to multiple users and unique custom reporting.

Build a Model

The model number starts with LIFTX followed by the desired options (Example: **LIFTX-N4**)

Options

- A24** - 24 VDC power supply for mA inputs
- D** - Blue poly mounting panel (18”T x 20”W)
- D1** - Mounts LIFTX inside MULTI-BOX (17”W x 14”H x 9”D)
- L** - (5) additional digital alarm inputs
- N4** - (4) 4-20mA isolated inputs
- N8** - (8) 4-20mA isolated inputs (O4 is not available with the N8 option)
- O4** - (4) 4-20mA isolated outputs
- R** - Adds 5 control relays, 120 VAC with pigtails, and mounts cell router in external enclosure
- S** - Delayed cell service start (up to 4 months)
- S1** - AT&T™ service instead of Verizon™ (no delayed start available)
- S2** - Cell router only, with no 12 months of data or SIM card
- W4** - (4) totalizing flow meter inputs with volume tracking and alarming

NOTES:

1. Base LIFTX units have 5 digital inputs, a built-in cell router, WebAdvantage access, and the first 12 months of cellular.
2. All units include 10 customizable notepad fields for manual reading test entry. These entries can generate alarms and are stored historically for graphing and reporting.
3. All units come standard with conduit connections for incoming power.
4. All required sensors must be sourced separately.

Advantage Controls offers a wide variety of monitoring, control, and pumping solutions for water/wastewater facilities:

- **Conductivity**
- **Temperature**
- **Turbidity**
- **pH/ORP**
- **Chlorine**
- **Tank/Basin Level**
- **Dissolved Oxygen**
- **Flow**
- **Pressure**

Visit www.advantagecontrols.com to learn more.

Specifications

Electrical Input: 95-240 VAC, 50/60 Hz

Relay Outputs: Dry contact relays pass through current is limited to 2.5mA at 28 VDC.

Display: 240 X 128 Graphic LCD

Digital Inputs: From open collector/open drain output or a dry contact. Inputs have 10K Ω pullup to 3.3 VDC.

Flow Totalizing Inputs: From open collector/open drain output or dry contact. Inputs use 10K Ω pullup to 5 VDC with a max input rate of 2.5 KHz.

mA Inputs: Optical isolation, 250 Ω / 5 VDC @ 20 mA. Loop voltage to not exceed 30 VDC.

mA Outputs: With non-isolated 12 VDC power from unit max load = 400 Ω. With isolated external 24 VDC power supply, max load = 800 Ω.

Enclosure: Heavy duty NEMA 4X style high impact ABS with padlockable, gasketed Lexan cover. Option **D1** available for harsh environments.

Environment

Ambient temperature: 0° to 125°F (-17° to 52°C)

Relative humidity: 0 to 100%

Shipping Weight: Approximately 8 lbs. (3.63 kg)

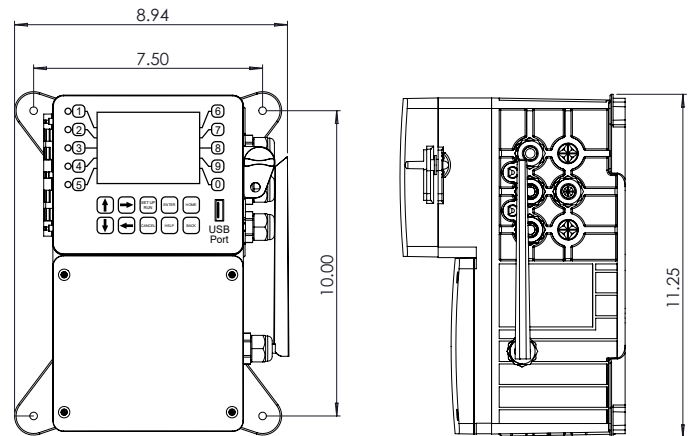

Get the Advantage