

Boiler Valve Stand

Free Standing Boiler Valve Assemblies

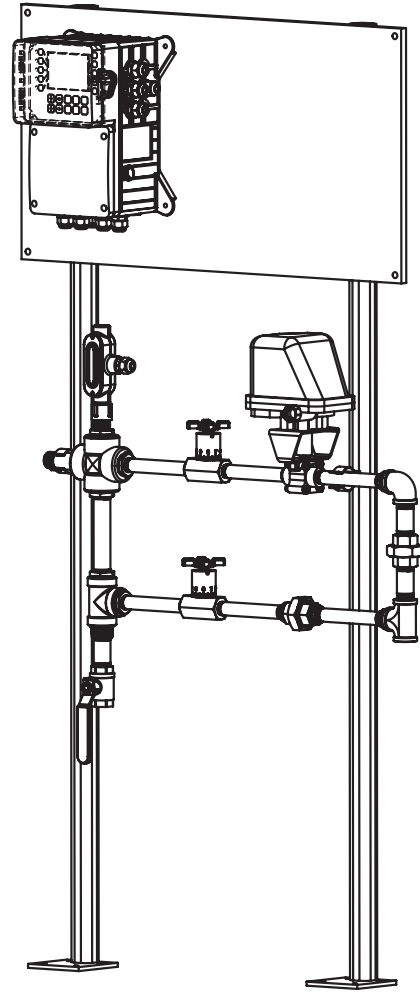

Key Features

- Simplify Installation
- Convenient Access
- Save Time & Money
- Professional Appearance
- Sample Stream Options
- Insures Configuration
- Corrosion Resistant Panel

Application

Advantage Controls BVS boiler prefab systems simplify boiler installations ensuring that controller, probe and blowdown valve are properly configured and wired.

BVS prefabs include a blowdown valve, throttling valve, probe cross with flush / sample valve mounted to 6' tall powder coated steel legs with floor mounts. There is a ½" blue poly panel section included for mounting separately ordered controller.

Give all of your boiler installations a professional appearance with the BVS.

Build a Model

BVS-30-30 uses MBWB-1/2 & NFC -1/2
BVS-50-30 uses MBV-050 & NFC -1/2

Options

- B** Bypass line with second NFC-1/2
- B3** Bypass line with probe on lower level w/ second NFC-1/2
- C** Continuous configuration w/ second NFC-1/2
- C1** Continuous configuration w/ second NFC-1/2 & MBWB-1/2
- C2** Continuous configuration w/second NFC-1/2 & MBV-050
- D** Adds a second sample stream & valves
- D1** Adds a second sample stream with MBV-050
- K4** Plumbing right to left
- L** Second 1/2" blue poly panel on lower section
- P** 3/4" probe cross instead of 1" cross
- S** Sample cooler (not pre-plumbed)
- S2** Sample cooler with hot inlet plumbed

Typical shipping weight..... 180lbs

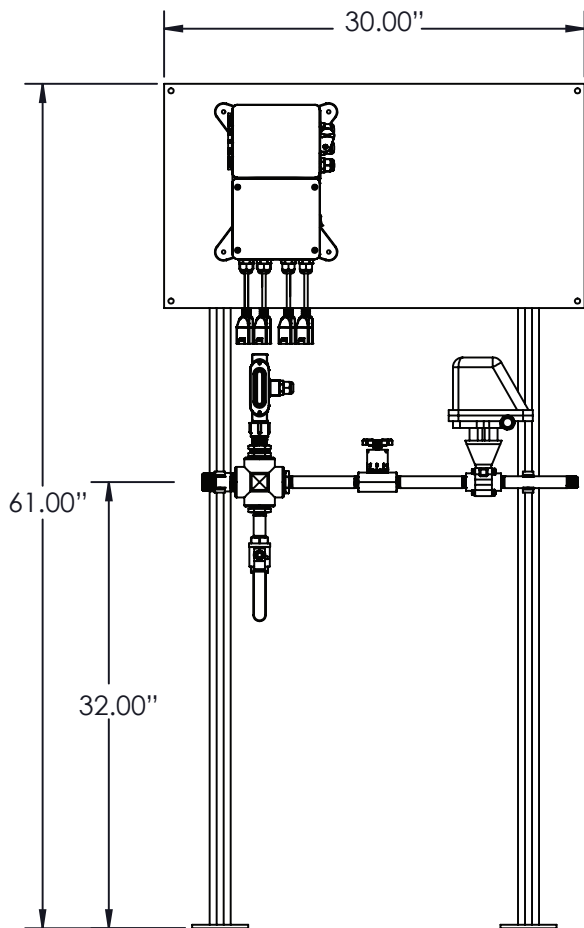

Valve Specifications

MBV

Max Fluid Temp. 459°F
 Max Boiler Pressure 325 PSIG
 Valve Body..... Carbon Steel
 Ball & Stem..... 316 SS
 Seals..... Teflon
 Shipping Weight 9 lbs.
 Actuator Ambient Max. 150°F
 Standard Electrical .. 120 VAC 2.3 Amp
 Sizes Available 1/2" & 3/4"



MBWB

Max Fluid Temp. 459°F
 Max Boiler Pressure 450 PSIG
 Valve Body..... Carbon Steel
 Ball & Stem..... 316 SS
 Seals..... Teflon
 Shipping Weight 9 lbs.
 Actuator Ambient Max. 150°F
 Standard Electrical .. 120 VAC 2.3 Amp
 Sizes Available 1/2" & 3/4"



NFC

Max Fluid Temp 600°F
 Max Boiler Pressure 5,000 PSIG
 Body Carbon Steel
 Stem 304 Stainless Steel
 Shipping Weight 4 lbs.
 Sizes Available 1/2" & 3/4"



LBC-SS

Max Fluid Temp 750°F
 Max Boiler Pressure 2,500 PSIG
 Body Carbon Steel
 Stem 316 SS
 Shipping Weight 13 lbs.
 Sizes Available 12"



Get the Advantage

