

ZIG-NANO

Wireless Transmitter

Installation
Maintenance
Repair
Manual

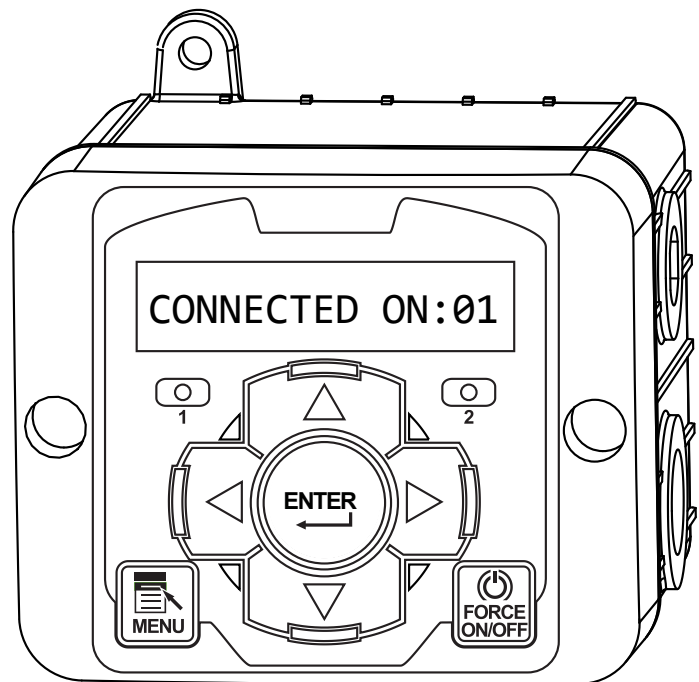

Advantage Controls
P.O. Box 1472
Muskogee, OK 74402
Phone: 800-743-7431
Fax: 888-686-6212
www.advantagecontrols.com
email: support@advantagecontrols.com

08/2017

Table of Contents

Contents	Page
I. Introduction.....	2
II. Description.....	3
ZIGR-NANO Features	3
ZIGB- NANO Featrues	3
III. Installation	
Electrical Wiring.....	3
Logic and Relay Cards	4
Mounting Instructions	4
IV. Front Panel Description	5
V. System Operation Overview.....	5
Description of Menus.....	5
VI. ZIGB-NANO Menu Map.....	6
VII. ZIGR-NANO Menu Map	7
VIII. Nano-to-Nano Remote Water Meter Installation	8
IX. Nano-to-Nano Remote Relay Installation	8
X. Nano-to-Nano Remote Digital Input	9
XI. Warranty & 30 Day Billing Memo Policy	10

I. Introduction

NanoTron microprocessor based controllers are designed to provide a wide range of control functions for recirculating water treatment systems. The controller is programmed through a front panel keypad and can be configured to provide a customized control system for your application. Your particular unit's functions can be determined by comparing the units model number to the model numbering table listed below.

Model Numbering

NanoTron units have several base system control functions and unit optional features. Your unit may be supplied with one or more of the features described in this manual. To determine what features apply to your unit check the model number label located on the controller enclosure.

Base Control Function

ZIGB-NANO - Base Model (2 pulse outputs)

ZIGR-NANO - Remote Model (2 relays, 2 digital inputs)

Whole Unit Optional Features

A - Conduit Connections

A3 - Conduit with CE

A7 - Australian power cord (240 VAC)

W - Larger enclosure with clear lockable cover

II. Description

NanoTron units are designed to automate the addition of various chemicals or activate other devices via a relay output.

ZIGR-NANO units include:

- * Two totalizing water meter inputs that can be configured for contacting head or hall effect meter inputs.
- * Two mechanical relay outputs with normally open and normally closed contacts that can be configured for powered or dry contact relay operation (see page 4).
- * A “force on” timer (remote models only) that allows for manual activation of the relays for a user defined amount of time.

ZIGB-NANO units include:

- * Two pulse outputs
- * Two dry contact inputs for relay control

III. Installation

General Safety Guideline

- Follow all safety guidelines outlined in this guide and/or marked on the unit.
- Never install or operate this product outside the specifications listed in this guide.
- Never install and operate in flammable or explosive environments.
- Install your unit in a location that is out of the reach of unauthorized personnel.
- Always install additional disconnect and safety devices to provide added protections.
- Never operate this product outside the environmental limits specified in this guide.

Condition of Use

This wireless system is not designed, intended or authorized for use in medical applications, applications intended to sustain or support life, in any nuclear facilities, or any other application where the failure of the product could create a situation where catastrophic property damage, personal injury, or death may occur. In the event that the Customer purchases or uses this product for any such unintended or unauthorized application, the Customer shall indemnify and hold harmless Advantage Controls and its officers, directors, employees, agents, affiliates, successors, and assigns against all claims, costs, damages, and expenses (including reasonable attorneys’ and expert witness’ fees) arising out of or in connection with such unintended or unauthorized use, even if such claim alleges that Advantage Controls and its affiliates was negligent regarding the design or manufacture of the subject product.

Electrical Wiring

The controller has an internal regulated power supply that will operate in the range of approximately 100 to 240 VAC on the incoming wiring. Output relay(s) are protected with a replaceable fuse. Relay output voltage will equal the incoming line voltage.

Prewired units are supplied with a 16 AWG cable with a 3-wire grounded USA 120 volt plug for incoming power and 18 AWG 3-wire grounded receptacle cords for all control relay outputs. Conduit units are supplied with liquid tights and adaptors for easy hard wiring to supplied connector.

NOTE: Liquid tight fittings and some labeled signal leads are provided for signal (low voltage) connections, such as water meter inputs.

Warning

1. **The controller should be connected to its own isolated circuit breaker, and for best results, the ground should be a true earth ground, not shared. Wiring must be done according to all applicable local codes.**
2. **Power (line voltage) must be disconnected while making any connections. If power is supplied to the unit, line voltage will be present on the relay cards.**
3. **Low voltage signal wires (probes, flow switch, water meter, etc.) should never be run in conduit with high voltage wires.**

Logic and Relay Cards

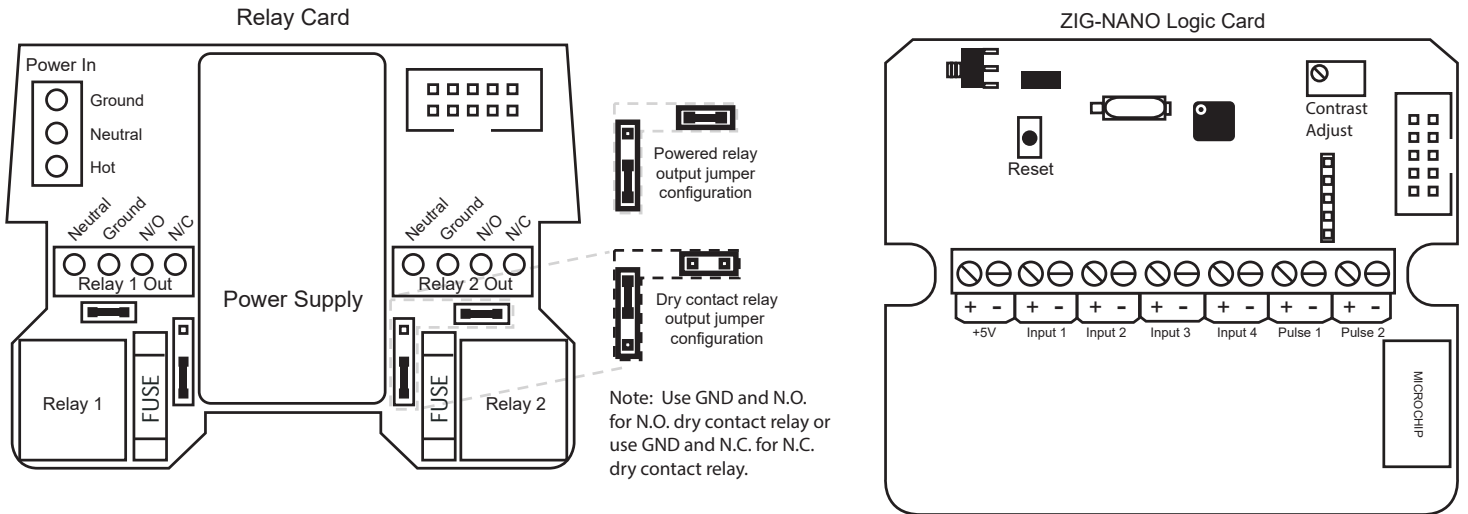

Mounting Instructions

Select a mounting location that provides the operator easy access to the unit and a clear view of the controls through the cover of the controller. The location should be convenient to grounded electrical connections, the needed sample line plumbing and is on a stable vertical surface.

WARNING: Avoid locations that expose the controller to direct sunlight, vapors, vibration, liquid spills or extreme temperatures; less than 0°F (-17.8°C) or greater than 120°F (50°C). EMI (electromagnetic interference) from radio transmissions and electric motors can also cause damage or interference and should be avoided.

General Specifications

Radio Frequency: 2.4 GHz
 Radio Protocol: IEEE Std. 802.15.4
 Comm Distance: 3,000 ft. line of sight
 Operating Temp: 0° F to 120° F
 Wire Connections: Terminal Block, 14-30 AWG
 Output Power Protection: 5A 120/240 VAC Fast Blow Fuses

IV. Front Panel Description

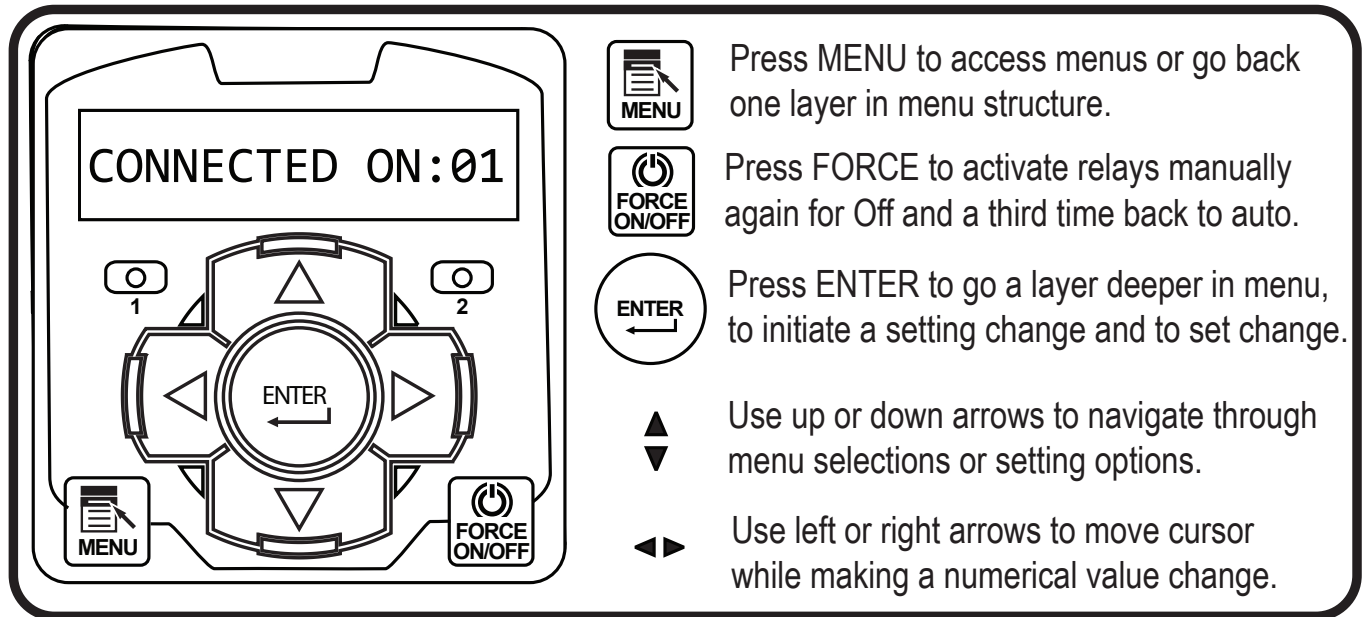

V. System Operation Overview

Description of Menus

NanoTron controllers have three modes of operation, Run, Menu and Force. All menus are circular. Pressing the DOWN key will display the next line of information on the display.

Run - This mode is for normal operation. The control relays will only be automatically active in this mode. In the Run mode, the display will read system values. If an alarm is present, the display flashes with the alarm status.

The Run menu will display values such as day, time, date and other values depending upon the features present on the unit. The unit will automatically return to the Run mode if no keys are pressed for three minutes.

Menu - This mode is used to make adjustments to settings and readings on the controller. To access the Menu mode from the run screen, press the Menu key. Use the up or down arrow to scroll through the various menus. When you want to access a specific menu, press the Enter key. Once you have entered a sub-menu you will be able to step through that menu's options with the up or down arrow key.

Force - Relays on NANO-ZIGR may be forced on or off for a user defined amount of time. Press the key to force relays on for the time configured in the Menu's force sub-menu. Press it a second time to force them off for the same amount of time. Press a third time to go back to automatic Run mode. Unit returns to the Run mode automatically when the force time has elapsed.

VI. ZIGB-NANO Menu Map

ZIGB-NANO Base Configuration

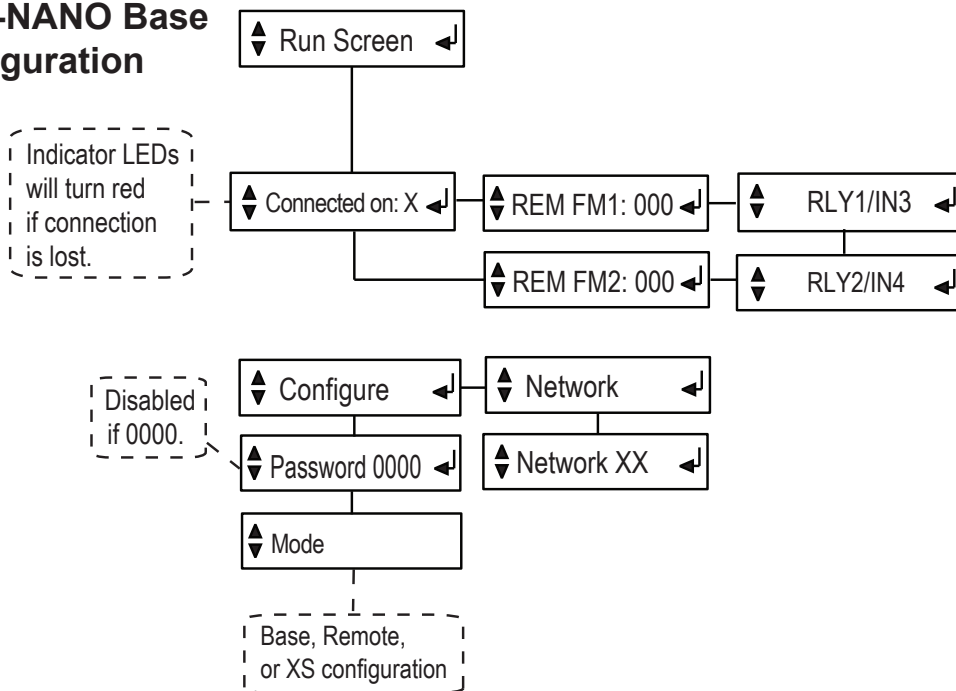

MENU Press MENU to access menus or go back one layer in menu structure.

FORCE ON/OFF Press FORCE to activate relays manually again for Off and a third time back to auto.

ENTER Press ENTER to go a layer deeper in menu, to initiate a setting change and to set change.

▲▼ Use up or down arrows to navigate through menu selections or setting options.

◀▶ Use left or right arrows to move cursor while making a numerical value change.

Note: If Menu is pressed while changing a value, the value on screen will be the new value.

VII. ZIGR-NANO Menu Map

ZIGR-NANO Remote Configuration

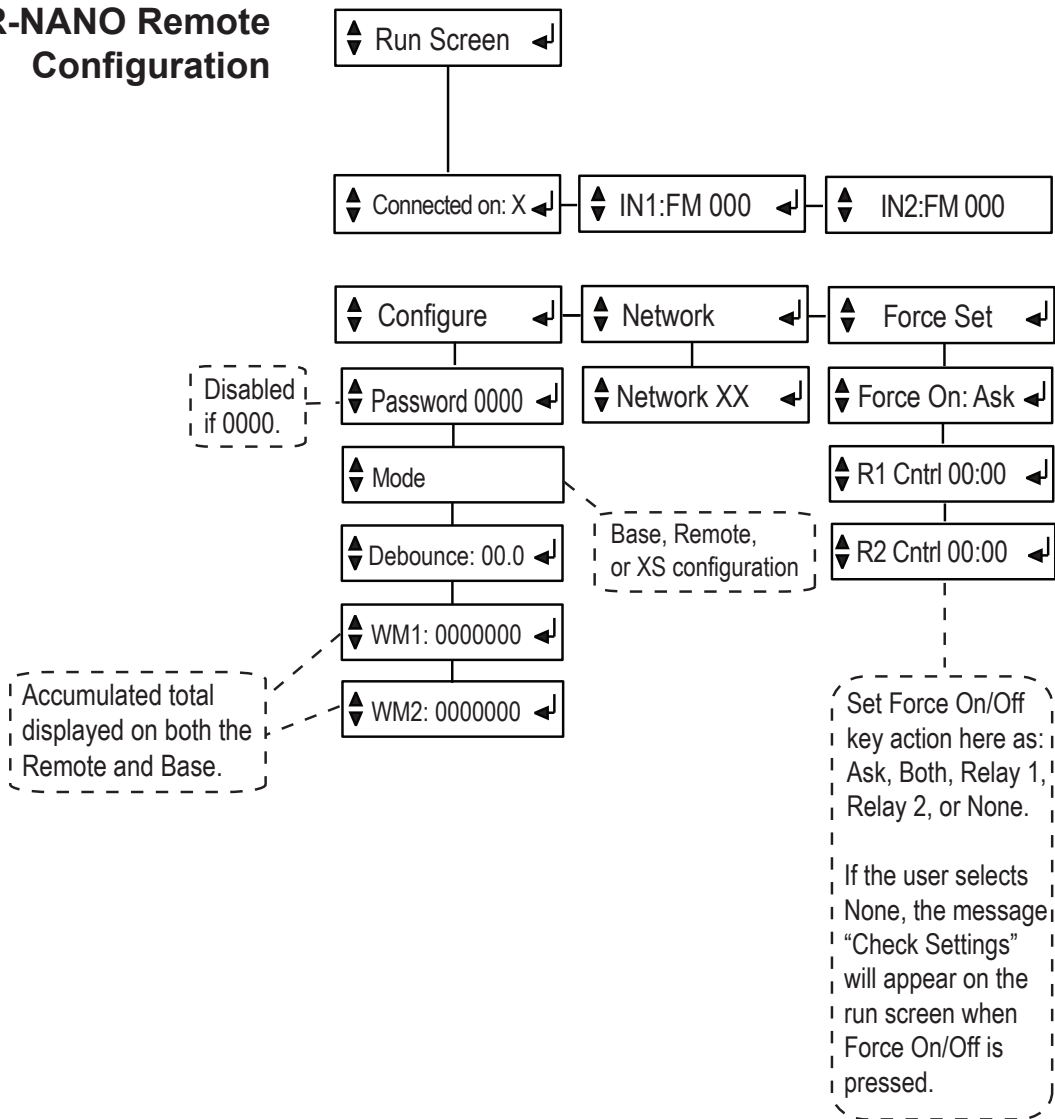

VIII. Nano-to-Nano Remote Water Meter Installation

1. Power on the “Base” unit and select the “Network” portion of the main menu. Select a network identifier from 1-99.
2. Power on the “Remote” unit and select the “Network” portion of the main menu. Select the same network identifier that was used on the “Base” unit. If both units are powered, then the message “CONNECTED ON: X” will appear on the run screen of both the “Base” and “Remote” units. “X” will be the selected network identifier.
3. Mount the “Remote” unit in a location near the desired water meter. Refer to the Mounting Instructions section of the manual for more detail.
4. Remove the two screws on the front of the “Remote” unit to access the terminal headers on the circuit board.
5. Connect the two wire dry contact output of the water meter into either the “Input 1” or “Input 2” headers on the “Remote” unit.
6. Replace the two screws mounting the faceplate of the “Remote” unit.
7. Mount the “Base” unit in a location near the host controller.
8. Remove the two screws on the front of the “Base” unit to access the terminal headers on the circuit board.
9. Connect a two wire cable from either the “Pulse 1” or “Pulse 2” headers on the “Base” unit into the desired water meter input header of the controller. “Pulse 1” from the “Base” unit will output the contacts received by “Input 1” on the “Remote” unit. “Pulse 2” from the “Base” unit will output the signal from “Input 2” on the “Remote” unit.
10. Replace the two screws mounting the faceplate of the “Base” unit.

IX. Nano-to-Nano Remote Relay Installation

1. Power on the “Base” unit and select the “Network” portion of the main menu. Select a network identifier from 1-99.
2. Power on the “Remote” unit and select the “Network” portion of the main menu. Select the same network identifier that was used on the “Base” unit. If both units are powered, then the message “CONNECTED ON: X” will appear on the run screen of both the “Base” and “Remote” units. “X” will be the selected network identifier.
3. Mount the “Remote” unit in a location near the relay controlled device. Refer to the Mounting Instructions section of the manual for more detail.
4. Plug the power cord of the relay controlled device into either the Relay 1 or Relay 2 pigtail of the “Remote” unit.
5. Mount the “Base” unit in a location near the host controller.
6. Remove the two screws on the front of the “Base” unit to access the terminal headers on the circuit board.
7. Configure and/or select the desired relay on the source controller to act as a dry contact output.
8. Connect a two wire cable from the dry contact output of the source controller to either the “Input 3” or “Input 4” headers on the “Base” unit. “Input 3” on the “Base” will control Relay 1 on the “Remote” unit. “Input 4” on the “Base” unit will control Relay 2 on the “Remote” unit.
9. Replace the two screws mounting the faceplate of the “Base” unit.

X. Nano-to-Nano Remote Digital Input

1. Power on the “Base” unit and select the “Network” portion of the main menu. Select a network identifier from 1-99.
2. Power on the “Remote” unit and select the “Network” portion of the main menu. Select the same network identifier that was used on the “Base” unit. If both units are powered, then the message “CONNECTED ON: X” will appear on the run screen of both the “Base” and “Remote” units. “X” will be the selected network identifier.
3. Mount the “Base” unit in a location near the desired dry contact output device. Refer to the Mounting Instructions section of the manual for more detail.
4. Remove the two screws on the front of the “Base” unit to access the terminal headers on the circuit board.
5. Connect the two wire dry contact output of the target device into either the “Input 3” or “Input 4” headers on the “Base” unit. “Input 3” on the “Base” will control Relay 1 on the “Remote” unit and “Input 4” on the “Base” unit will control Relay 2 on the “Remote” unit.
6. Replace the two screws mounting the faceplate of the “Base” unit.
7. Mount the “Remote” unit in a location near the host controller.
8. Remove the two screws on the front of the “Remote” unit to access the relay board.
9. Change both relays into their dry contact configuration. Refer to the relay card drawing for more details.
10. Connect a two wire cable from the “GND” and “N/O” positions on either Relay 1 or Relay 2 of the “Remote” unit into the desired digital input of the host controller.
11. Replace the two screws mounting the faceplate of the “Remote” unit.

XI. Manufacturer's Product Warranty

Advantage Controls warrants units of its manufacture to be free of defects in material or workmanship. Liability under this policy extends for 24 months from date of installation. Liability is limited to repair or replacement of any failed equipment or part proven defective in material or workmanship upon manufacturer's examination. Removal and installation costs are not included under this warranty. Manufacturer's liability shall never exceed the selling price of equipment or part in question.

Advantage disclaims all liability for damage caused by its products by improper installation, maintenance, use or attempts to operate products beyond their intended functionality, intentionally or otherwise, or any unauthorized repair. Advantage is not responsible for damages, injuries or expense incurred through the use of its products.

The above warranty is in lieu of other warranties, either expressed or implied. No agent of ours is authorized to provide any warranty other than the above.

30 Day Billing Memo Policy

Advantage Controls maintains a unique factory exchange program to ensure uninterrupted service with minimum downtime. If your unit malfunctions, call 1-800-743-7431, and provide our technician with Model and Serial Number information. If we are unable to diagnose and solve your problem over the phone, a fully warranted replacement unit will be shipped, usually within 48 hours, on a 30 Day Billing Memo.

This service requires a purchase order and the replacement unit is billed to your regular account for payment.

The replacement unit will be billed at current list price for that model less any applicable resale discount. Upon return of your old unit, credit will be issued to your account if the unit is in warranty. If the unit is out of warranty or the damage not covered, a partial credit will be applied based upon a prorated replacement price schedule dependent on the age of the unit. Any exchange covers only the controller or pump. Electrodes, liquid end components and other external accessories are not included.

FCC Warning

This equipment generates and uses radio frequency energy and if not installed and used properly, that is, in strict accordance with the manufacturer's instruction, may cause interference to radio communications. It has been type tested and found to comply with the limits for a class A computing device pursuant to subpart J of part 15 of FCC Rules, which are designed to provide reasonable protection against such interference when operated in a commercial or industrial environment. Operation of this equipment in a residential area is likely to cause interference in which case the user, at his own expense, will be required to take whatever measures necessary to correct the interference.

Get the Advantage in Water Treatment Equipment

Advantage Controls can give you the *Advantage* in products, knowledge and support on all of your water treatment equipment needs.

- Cooling Tower Controllers
- Boiler Blow Down Controllers
- Blow Down Valve Packages
- Solenoid Valves
- Water Meters
- Chemical Metering Pumps
- Corrosion Coupon Racks
- Chemical Solution Tanks
- Solid Feed Systems
- Feed Timers
- Filter Equipment
- Glycol Feed Systems
- Pre Fabricated Systems

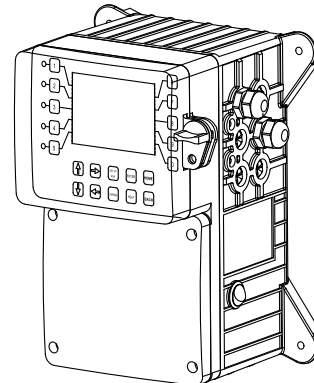
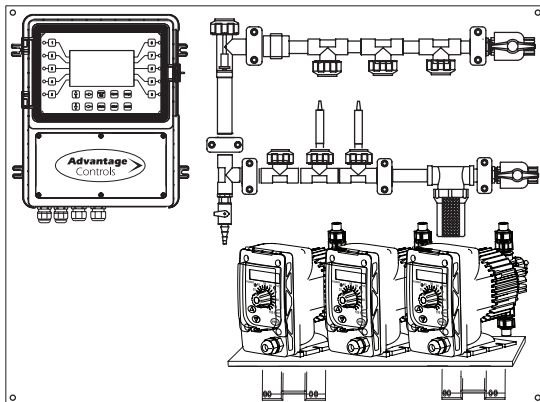
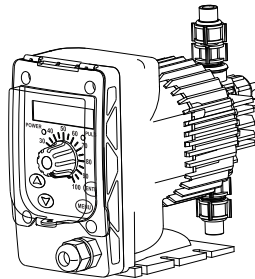
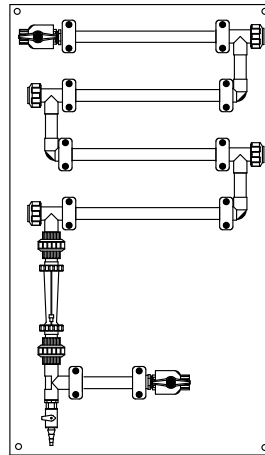
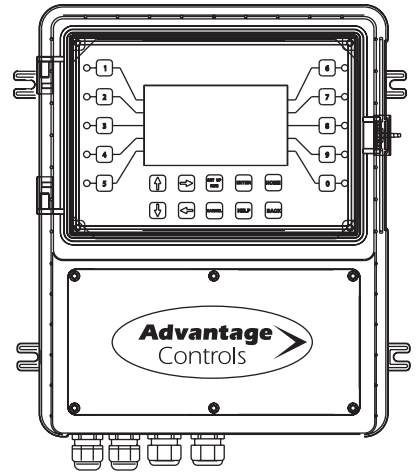
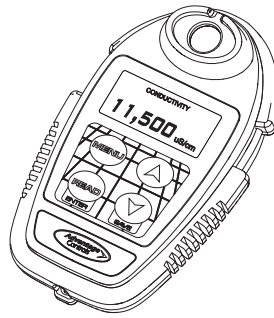

Get the Advantage

